

DS-59TYJ-2B AC Permanent Magnet Synchronous Motor DongShun



Main voltage: 12VAC, 24VAC, 110VAC, 115VAC, 220VAC, 240VAC

Typical applications: Office Machines, CCTV Scanner & Pan /Tilt Units, Automatic Control Machines, Spotlights, Toys and Presents, Recorders, Air Conditioner, Micro Wave Ovens, Display Stand, Ventilating, Electric Fans, Household Electrics, Laminator, Oven, Electronic Timer, Washing machine timer, Other household appliances.

Weight: 500~550g/pcs(approx)

Packing details: CTN size: 49X37XH18cm 40pcs/CTN G.W.23Kgs

APPEARANCE SIZE

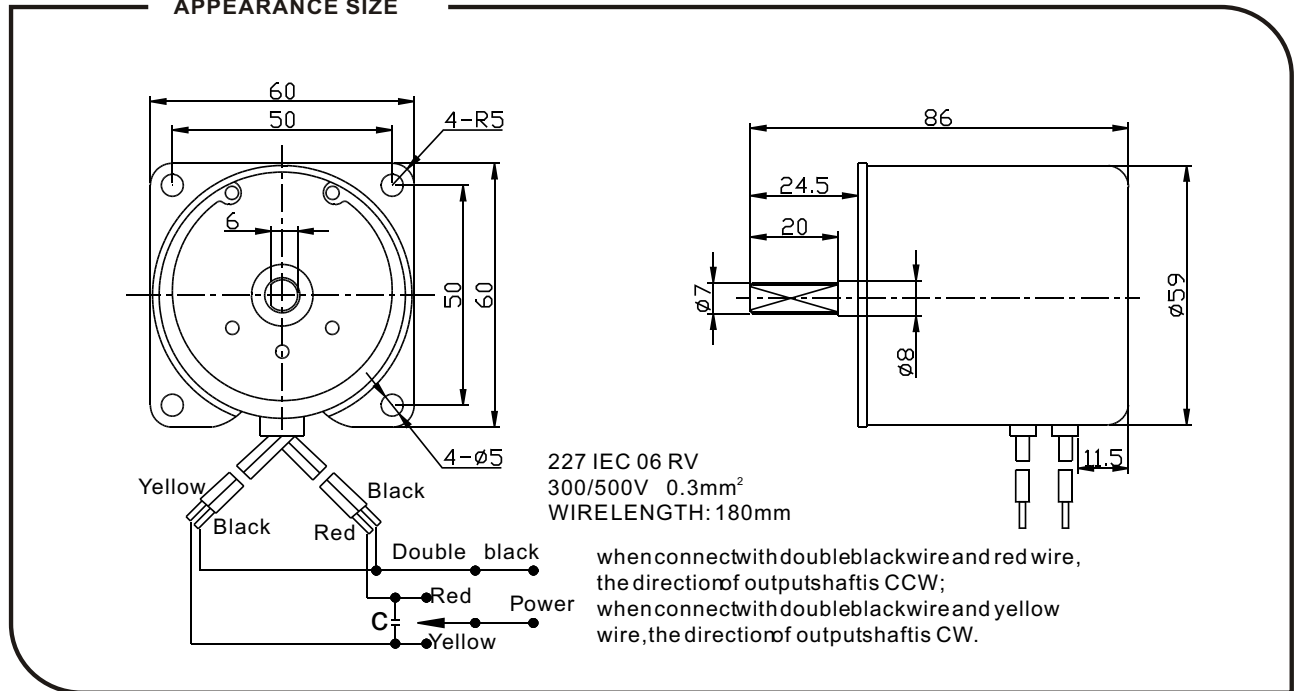

Main technical data:

Model	DS-59TYJ-2B					
Tech.items						
Related voltage (V)	AC24V、 AC120V、 AC220V					
Frequency (Hz)	50/60					
Speed(at50Hz)(r/min)	5.0	8.0	15	20	60	100
Torque (Kgf.cm)	34	22	14	10	4	2.5
Related current (mA)	≤55(220V)		≤100(120V)		≤400(24V)	
Input Power (w)	≤11					
Noise (dB)	42					
Insulation strength	AC 1500V-1min cut off current :10mA					
Leakage current	≤0.25mA					
Insulation resistance	500VDC ≥100MΩ					
Direction of rotation	CW or CCW(Bi-directional controllable)					
Package details	CTN:49X37XH18 40pcs/CTN N.W.23Kg					